

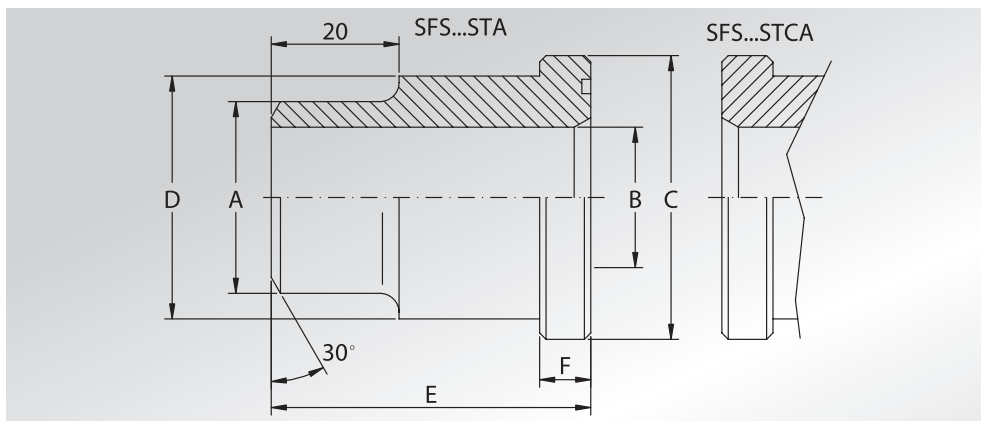

**CODOLI  
A SALDARE DI  
TESTA  
PER TUBO GAS**

**WELD  
ON ADAPTERS  
FOR BSP TUBE**



Pressione max di esercizio raccomandata Kg/cm <sup>2</sup>	Grandezza	Tipo	Dimensioni						Or tipo	Peso Kg
Maximum recommended working pressure Kg/cm <sup>2</sup>	Size	Type	Dimensions						Or type	Weight Kg
			A	B	C	D	E	F		

### SERIE 3000

345	1/2"	SFS301STA21	21,5	13	30,2	24	41	6,73	4075	0,08
345	3/4"	SFS302STA28	28,0	19	38,1	32	50	6,73	4100	0,16
345	1"	SFS303STA34	34,0	25	44,4	38	50	8,00	4131	0,23
276	1"1/4	SFS304STA42	42,8	32	50,8	43	55	8,00	4150	0,30
207	1"1/2	SFS305STA48	48,6	38	60,3	50	57	8,00	4187	0,40
207	2"	SFS306STA61	61,0	51	71,4	62	57	9,53	4225	0,50

### SERIE 6000

414	1/2"	SFS601STA21	21,5	13	31,8	24	34	7,75	4075	0,08
414	3/4"	SFS602STA28	28,0	19	41,3	32	38	8,76	4100	0,15
414	1"	SFS603STA34	34,0	25	47,6	38	40	9,53	4131	0,23
414	1"1/4	SFS604STA42	42,8	32	54,0	44	45	10,29	4150	0,30
414	1"1/2	SFS605STA48	48,6	38	63,5	51	50	12,57	4187	0,50
414	2"	SFS606STA61	61,0	51	79,4	67	58	12,57	4225	0,80

DESIGNAZIONE PER ORDINE DESIGNATION FOR ORDER	Materiale / Material	
	A105 o similare (or similar)	AISI 316L
Codolo con sede o-ring Adapter with o-ring groove	<b>SFS...STA</b>	<b>SFX...STA</b>
Codolo senza sede o-ring Adapter without o-ring groove	<b>SFS...STCA</b>	<b>SFX...STCA</b>