

CODOLI A SALDARE DI TESTA PER TUBO METRICO

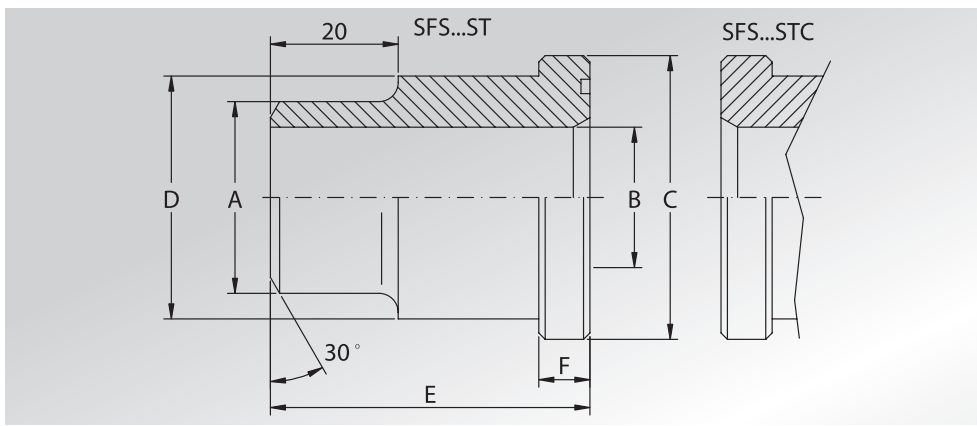

WELD ON ADAPTERS FOR METRIC TUBE



Pressione max di esercizio raccomandata Kg/cm ²	Grandezza	Tipo	Dimensioni						Or tipo	Peso Kg
Maximum recommended working pressure Kg/cm ²	Size	Type	Dimensions						Or type	Weight Kg
			A	B	C	D	E	F		

SERIE 3000

345	1/2"	SFS301ST	16	12	30,2	24	41	6,73	4075	0,08
345	3/4"	SFS302ST	25	19	38,1	32	50	6,73	4100	0,16
345	1"	SFS303ST	30	22	44,4	38	50	8,00	4131	0,23
276	1"1/4	SFS304ST	38	28	50,8	43	55	8,00	4150	0,30
207	1"1/2	SFS305ST	45	35	60,3	50	57	8,00	4187	0,40
207	2"	SFS306ST	60	50	71,4	62	57	9,53	4225	0,50
172	2"1/2	SFS307ST	70	55	84,1	74	58	9,53	4275	0,80
138	3"	SFS308ST	80	68	101,6	90	60	9,53	4337	1,10
34	3"1/2	SFS309ST	100	89	114,3	102	80	11,20	4387	1,40
34	4"	SFS310ST	114,3	99	127,0	114,3	80	11,20	4437	1,75
34	5"	SFS311ST	139,7	120	152,4	139,7	80	11,20	4537	2,62

SERIE 6000

414	1/2"	SFS601ST	16	12	31,8	24	34	7,75	4075	0,08
414	3/4"	SFS602ST	25	18	41,3	32	38	8,76	4100	0,15
414	1"	SFS603ST	30	22	47,6	38	40	9,53	4131	0,23
414	1"1/4	SFS604ST	38	27	54,0	44	45	10,29	4150	0,30
414	1"1/2	SFS605ST	45	32	63,5	51	50	12,57	4187	0,50
414	2"	SFS606ST	60	45	79,4	67	58	12,57	4225	0,80
414	2"1/2	SFS607ST	76	63	107,8	88,9	90	20,6	4275	2,30
414	3"	SFS608ST	90	58	131,7	113,8	110	25,6	4337	6,40

PER QUESTA TIPOLOGIA DI PRODOTTO, VERIFICATE SEMPRE SE LA QUOTA "A" E "B" CORRISPONDE ALLA SCHEDULA DEL VOSTRO TUBO

FOR THIS KIND OF PRODUCT, PLEASE ALWAYS VERIFY IF DIMENSION "A" AND "B" CORRESPOND TO THE SCHEDULE OF YOUR TUBE

DESIGNAZIONE PER ORDINE DESIGNATION FOR ORDER	Materiale / Material	
	A105 o similare (or similar)	AISI 316L
Codolo con sede o-ring Adapter with o-ring groove	SFS...ST	SFX...ST
Codolo senza sede o-ring Adapter without o-ring groove	SFS...STC	SFX...STC