

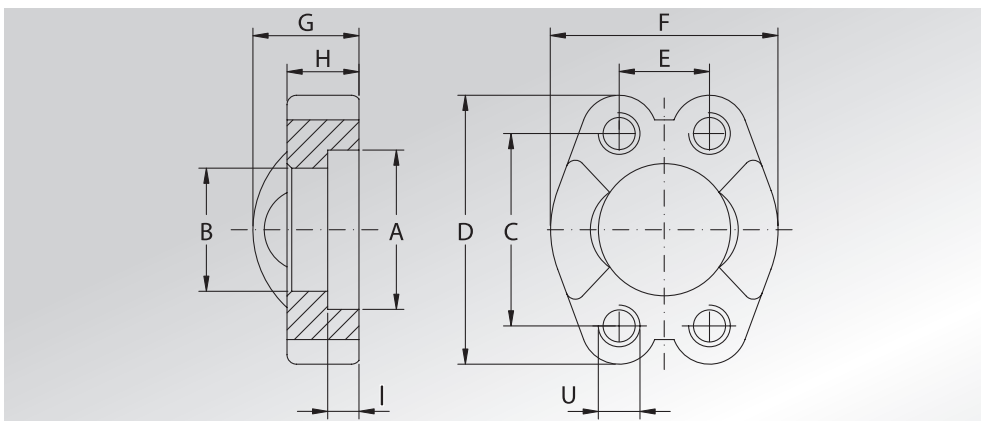

SEMIFLANGE INTERE CON FORI DI FISSAGGIO FILETTATI UNC

**UNCUT SPLIT FLANGES
WITH UNC THREADED
FIXING HOLES**



Pressione max di esercizio raccomandata Kg/cm ²	Grandezza	Tipo	Dimensioni										Peso Kg
Maximum recommended working pressure Kg/cm ²	Size	Type	Dimensions										Weight Kg
			A	B	C	D	E	F	G	H	I	U	

SERIE 3000

345	1/2"	GFSI301UB	30,96	24,26	38,10	54	17,48	45,6	19	13	6,22	5/16"	0,12
345	3/4"	GFSI302UB	38,89	32,13	47,63	65	22,23	51,8	22	14	6,22	3/8"	0,16
345	1"	GFSI303UB	45,24	38,48	52,37	70	26,19	58,4	24	16	7,49	3/8"	0,22
276	1"1/4	GFSI304UB	51,59	43,69	58,72	79	30,18	72,6	22	14	7,49	7/16"	0,30
207	1"1/2	GFSI305UB	61,09	50,80	69,85	94	35,71	82,2	25	16	7,49	1/2"	0,43
207	2"	GFSI306UB	72,24	62,74	77,77	102	42,88	96,4	26	16	9,02	1/2"	0,56
172	2"1/2	GFSI307UB	84,94	74,93	88,90	114	50,80	108,2	38	19	9,02	1/2"	0,74
138	3"	GFSI308UB	102,39	90,93	106,38	135	61,93	130,6	41	22	9,02	5/8"	1,30
34	3"1/2	GFSI309UB	115,10	102,36	120,65	152	69,85	139,0	28	22	10,72	5/8"	1,27
34	4"	GFSI310UB	127,79	115,06	130,18	162	77,77	152,0	35	25	10,72	5/8"	1,65
34	5"	GFSI311UB	153,19	140,46	152,40	184	92,08	180,0	41	28	10,72	5/8"	2,50

SERIE 6000

414	1/2"	GFSI601UB	32,54	24,64	40,49	56	18,24	47,2	22	16	7,24	5/16"	0,16
414	3/4"	GFSI602UB	42,06	32,51	50,80	71	23,80	60,0	28	19	8,26	3/8"	0,34
414	1"	GFSI603UB	48,41	38,86	57,15	81	27,76	69,6	33	24	9,02	7/16"	0,51
414	1"1/4	GFSI604UB	54,76	44,45	66,68	95	31,75	77,2	38	27	9,78	1/2"	0,80
414	1"1/2	GFSI605UB	64,29	51,56	79,38	113	36,50	95,0	43	30	12,07	5/8"	1,44
414	2"	GFSI606UB	80,16	67,56	96,82	133	44,45	113,8	52	37	12,07	3/4"	2,10



SEMIFLANGE PIATTE INTERE CON FORI DI FISSAGGIO FILETTATI UNC

**UNCUT FLAT SPLIT
FLANGES WITH UNC
THREADED FIXING
HOLES**

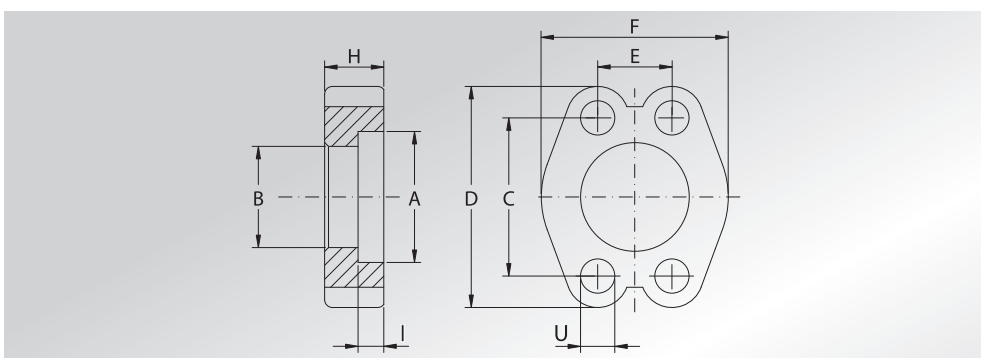

414	2"1/2	GFPFI607 *	108,5	89,50	123,8	180	29,35	76,0	-	45	20,00	7/8"	4,90
414	3"	GFPFI608 *	132,5	114,50	152,4	208	35,7	89,0	-	55	25,00	1"1/8	7,30

DESIGNAZIONE PER ORDINE DESIGNATION FOR ORDER	Materiale / Material	
	S355	AISI 316L
Semiflangua intera con fori di fissaggio metrici Uncut split flange with metric threaded fixing holes	GFSI...UB GFPI...U	GFXI... GFPXI...U

NOTE / NOTES

Rivestimento superficiale : zincatura Cr3
Superficial coating : zinking Cr3

* NON ZINCATE
* NOT ZINKING