

**FLANGE  
A SALDARE DI  
TESTA  
TUBO METRICO  
FORO CILINDRICO**

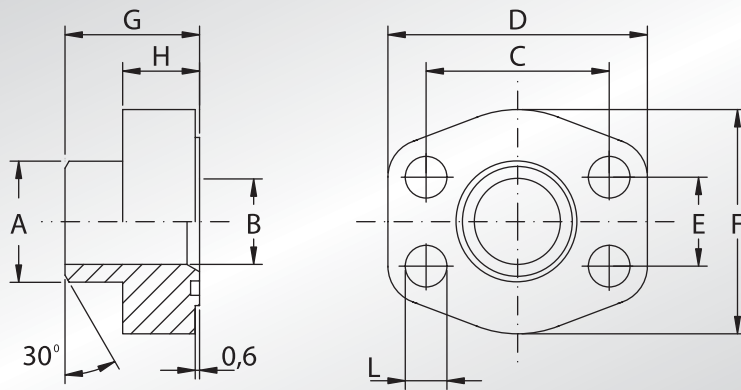

**METRIC PIPE  
CYLINDRIC HOLE  
WELD ON FLANGES**



Pressione max di esercizio raccomandata Kg/cm <sup>2</sup>	Grandezza	Tipo	Dimensioni									Viti		Or tipo	Peso Kg
Maximum recommended working pressure Kg/cm <sup>2</sup>	Size	Type	Dimensions									Screws		Or type	Weight Kg
			A	B	C	D	E	F	G	H	L	Metric	Unc		

**SERIE 3000**

345	3/4"	AFS100SRE25	25	19	47,63	65	22,23	50	36	18	11	M10x35	3/8x1"1/2	4100	0,35
345	1"	AFS102SRE30	30	22	52,37	70	26,19	55	38	18	11	M10x35	3/8x1"1/2	4131	0,41
276	1"1/4	AFS104SRE38	38	30	58,72	79	30,18	68	41	21	11,5	M10x40	7/16x1"3/4	4150	0,64
207	1"1/2	AFS106SRE42	42	36	69,85	93	35,71	78	44,5	24,5	13,5	M12x45	1/2x1"3/4	4187	0,98
207	1"1/2	AFS106SRE48	49	38	69,85	93	35,71	78	44,5	24,5	13,5	M12x45	1/2x1"3/4	4187	0,98
207	2"	AFS108SRE48	49	42	77,77	102	42,88	90	45	25	13,5	M12x45	1/2x1"3/4	4225	1,14
207	2"	AFS108SRE60	61	49	77,77	102	42,88	90	45	25	13,5	M12x45	1/2x1"3/4	4225	1,14
172	2"1/2	AFS110SRE76	77	62	88,90	114	50,80	105	50	25	13,5	M12x45	1/2x1"3/4	4275	1,55
138	3"	AFS112STRE76	77	70	106,38	134	61,93	124	51	26	17,5	M16x50	5/8x2"	4337	2,33
138	3"	AFS112SRE76	77	62	106,38	134	61,93	124	51	26	17,5	M16x50	5/8x2"	4337	2,33
34	3"1/2	AFS114STRE76	77	70	120,65	152	69,85	136	48	26	17,5	M16x50	5/8x2"	4387	2,40
34	3"1/2	AFS114STRE88	90	82	120,65	152	69,85	136	48	26	17,5	M16x50	5/8x2"	4387	2,40
34	4"	AFS116STRE76	77	70	130,18	162	77,77	146	48	26	17,5	M16x50	5/8x2"	4437	2,85
34	4"	AFS116STRE88	90	82	130,18	162	77,77	146	48	26	17,5	M16x50	5/8x2"	4437	2,85

**SERIE 6000**

414	1/2"	AFS401SRE20	20	14	40,49	57	18,24	46	34	16	9	M8x30	5/16x1"1/4	4075	0,24
414	3/4"	AFS402SRE20	20	14	50,80	71	23,80	55	35	21	11	M10x40	3/8x1"1/2	4100	0,48
414	3/4"	AFS402SRE25	25	17	50,80	71	23,80	55	35	21	11	M10x40	3/8x1"1/2	4100	0,48
414	1"	AFS403SRE25	25	19	57,15	81	27,76	65	42	25	13	M12x45	7/16x1"3/4	4131	0,64
414	1"	AFS403SRE30	30	22	57,15	81	27,76	65	42	25	13	M12x45	7/16x1"3/4	4131	0,64
414	1"1/4	AFS404SRE38	38	28	66,68	95	31,75	78	44	25	15 *	M14x45	1/2x1"3/4	4150	1,00
414	1"1/4	AFS404SRE38B26	38	26	66,68	95	31,75	78	44	25	15 *	M14x45	1/2x1"3/4	4150	1,00
414	1"1/2	AFS405SRE38	38	28	79,38	112	36,50	94	56	28	17	M16x50	5/8x2"	4187	1,69
414	1"1/2	AFS405SRE48B32	48,6	32	79,38	112	36,50	94	56	28	17	M16x50	5/8x2"	4187	1,69
414	2"	AFS406SRE60	61	40	96,82	134	44,45	114	65	37	21	M20x70	3/4x2"1/2	4225	2,86
414	2"1/2	AFS507SRE76	76,6	50	123,80	180	58,70	152	80	45	26	M24x80	—	4275	6,40

**DESIGNAZIONE PER ORDINE  
DESIGNATION FOR ORDER**

Solo flangia  
Only flange

Flangia completa di viti metriche, grower e o-ring  
Flange complete of metric screws, grower type washers and o-ring

Flangia completa di viti unc, grower e o-ring  
Flange complete of unc screws, grower type washers and o-ring

**Materiale / Material**

**ST52.3**      **AISI 316L**

**AFS...SRE/STRE**      **AFX...SRE/STRE**

**AFS...SRE...M/STRE...M**      **AFX...SRE...M/STRE...M**

**AFS...SRE...U/STRE...U**      **AFX...SRE...U/STRE...U**

**NOTE / NOTES**

\* Per viti unc L=13,5  
\* For unc screws L=13,5

(•) Solo in ST52.3  
(•) Only in ST52.3

set viti unc disponibili solo in acciaio al carbonio.  
unc screws set available only in carbon steel.