

**FLANGE 90°
FILETTATE
METRICHE CON
ATTACCO
DIN 3901-3902**

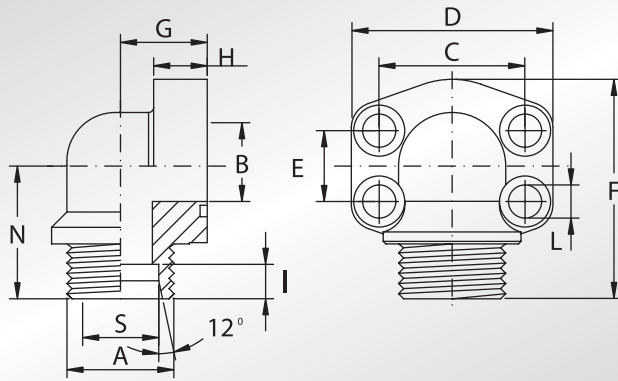

**DIN 3901-3902
METRIC THREADED
90° FLANGES**



Pressione max di esercizio raccomandata Kg/cm ²	Grandezza	Tipo	Dimensioni											Viti		Or tipo	Peso Kg	
Maximum recommended working pressure Kg/cm ²	Size	Type	Dimensions											Screws		Or type	Weight Kg	
			A	B	C	D	E	F	G	H	I	L	N	S	Metric	Unc		

SERIE 3000

345	1/2"	AFS08090E	M22x1,5	12	38,10	54	17,48	60	20	16	7	9	37	15	M8x30	5/16x1"1/4	4075	0,25
345	3/4"	AFS10090E	M30x2	19	47,63	65	22,23	65	24	18	7,5	11	40	22	M10x35	3/8x1"1/2	4100	0,38
345	1"	AFS10290E	M36x2	25	52,37	70	26,19	70	28	19	12,0	11	43	28	M10x35	3/8x1"1/2	4131	0,49
276	1"1/4	AFS10490E	M45x2	32	58,72	79	30,18	86	34	21	10,5	11,5	52	35	M10x40	7/16x1"3/4	4150	0,77
207	1"1/2	AFS10690E	M52x2	38	69,85	93	35,71	95	38	25	11,0	13,5	56	42	M12x45	1/2x1"3/4	4187	1,10

SERIE 6000

414	1/2"	AFS40190E	M24x1,5	12	40,49	54	18,24	60	20	16	8,5	9	37	16	M8x30	5/16x1"1/4	4075	0,28
414	3/4"	AFS40290E	M36x2	19	50,80	70	23,80	70	28	19	12,0	11	43	25	M10x35	3/8x1"1/2	4100	0,69
414	1"	AFS40390E	M42x2	25	57,15	79	27,76	85	34	21	13,5	13	52	30	M12x45	7/16x1"3/4	4131	1,11
414	1"1/4	AFS40490E	M52x2	32	66,68	93	31,75	95	38	25	16,0	15 *	56	38	M14x45	1/2x1"3/4	4150	1,45
414	1"1/2	AFS40590E	M52x2	38	79,38	110	36,50	110	42	25	16,0	17	65	38	M16x50	5/8x2"	4187	2,75

**DESIGNAZIONE PER ORDINE
DESIGNATION FOR ORDER**

	Materiale / Material	
	ST52.3	AISI 316L
Solo flangia Only flange	AFS...90E	AFX...90E
Flangia completa di viti metriche, grower e o-ring Flange complete of metric screws, grower type washers and o-ring	AFS...90EM	AFX...90EM
Flangia completa di viti unc, grower e o-ring Flange complete of unc screws, grower type washers and o-ring	AFS...90EU	AFX...90EU

NOTE / NOTES

* Per viti unc L=13,5
* For unc screws L=13,5

set viti unc disponibili solo in acciaio al carbonio.
unc screws set available only in carbon steel.